

## RF EMP Protector 130 MHz center, 400W, N – N Jack USS-SL-N-130

**Protection for 50 Ohm coaxial cables, based on quarter wave stub technology**

**For RF-power up to 400 W**

**Low insertion loss operation from 117 to 143 MHz**

**N-jack (female) for Input and Output**

**Tuned to 130 MHz**

**Very low residual energy protection against overvoltages produced by NEMP / HEMP, lightning or other transients**

**High surge current capability**



The Meteolabor® USS-SL-series RF EMP protectors are specially designed for the protection of coaxial lines. High surge currents on the inner conductor can be handled.

The USS-SL-series products are based on quarter wave stub technology, sometimes also referred to as  $\lambda/4$  stub. This technology offers lowest possible insertion loss in the pass-band, while blocking DC and low frequencies.

Various transient protection designs for broadband or limited frequency band operation are available. Generally limited frequency band elements provide lower residual energy in the case of transient overvoltages such as produced by atmospheric discharges (lightning, electrostatic discharge) or a High Altitude Electro-Magnetic Pulse (HEMP), sometimes also referred to as Nuclear Electro-Magnetic Pulse (NEMP) or simply EMP.

### Applications

The Meteolabor® USS-SL-N-130 RF EMP surge protector element ensures best protection of a broadband 50 Ohm coaxial line of telecommunication equipment etc. against transient overvoltages (e.g. NEMP / HEMP, lightning).

USS-SL-N-130 is best suited for lines using N connectors, working around the center frequency of 130 MHz with RF-power up to 400 W.

Applications range from mission critical equipment, such as fixed or mobile military installations (e.g. C<sup>4</sup>I facilities) to civilian or industrial projects, requiring high reliability and state-of-the-art protection.

USS-SL-N-130 has been successfully used in many projects, where HEMP-testing according to RS-105 on threat-level has been conducted

### Technical Data USS-SL-N-130

Application	50 Ohm coaxial line	For RF applications with center frequency 130MHz
Max. operating power	400 W	Matched load
Max. surge current $I_{Max}$	25 kA	Inner conductor → ground, shape 8/20 $\mu$ s, single pulse
Nominal surge current $I_N$	25 kA	Inner conductor → ground, shape 8/20 $\mu$ s, 10 pulses at 30s intervals
Tuning frequency	130 MHz	Factory tuned center frequency
Frequency range	117 to 143 MHz	Insertion loss $\leq$ 0.1 dB
Frequency range	115 to 150 MHz	Insertion loss $\leq$ 0.2 dB
Frequency range	90 to 170 MHz	Insertion loss $\leq$ 0.5 dB
Return loss	$\geq$ 15 dB	117 to 143 MHz
DC resistance	3 m $\Omega$	Typical value
Connectors	N jack (female)	Unprotected and protected side
Operating temperature	-40°C to +85°C	
Ingress protection	IP 65	when coupled with conform mating connectors
Dimensions	370 x 46 mm	Major dimensions, details see drawing
Weight	approx. 250 g	

### Dimensions [mm]

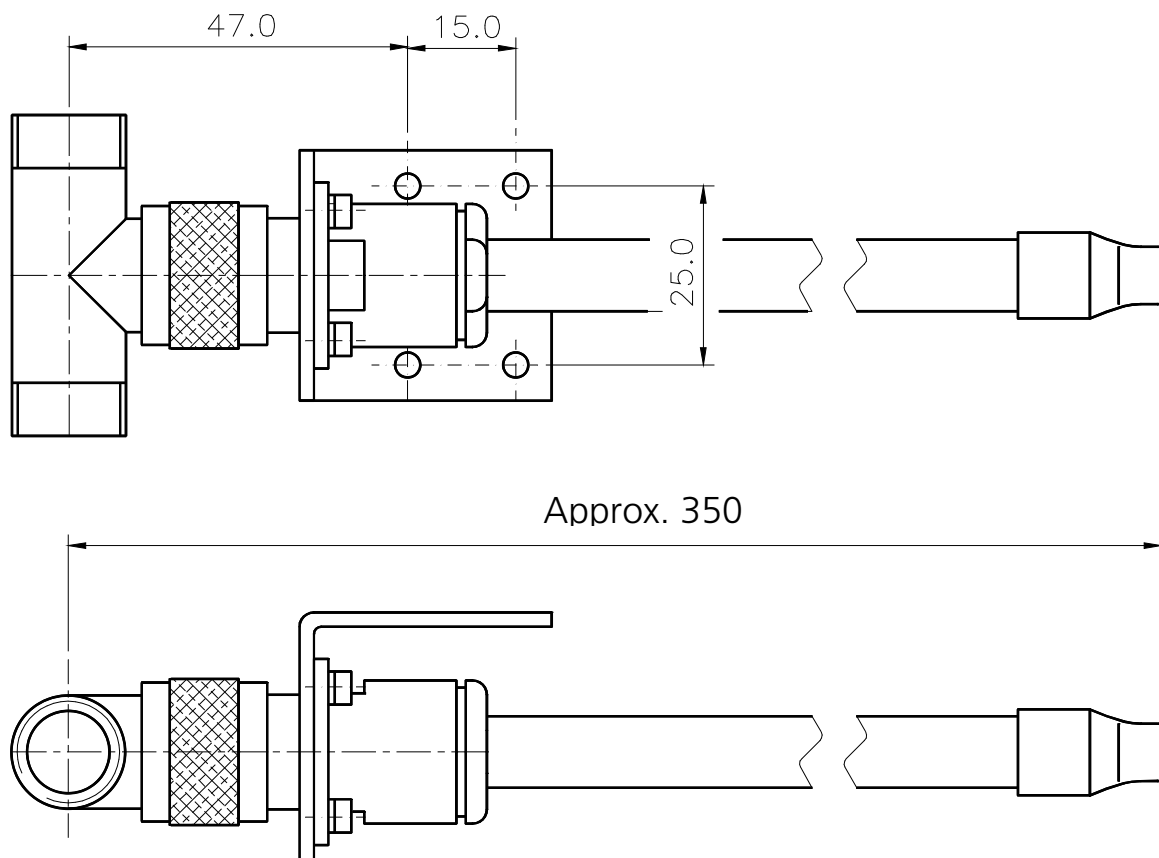

### Installation Notes

- EMP protectors shall be installed by electrically skilled personnel.
- The electrical wiring must be done according to local regulations.
- The max. values stated in this datasheet must not be exceeded under any circumstances.
- Carefully observe General Recommendations for Protection Installation in this datasheet.

### General Recommendations for Protection Installation

- In order to achieve the full performance of a protection circuit the application of good-practice EMC design techniques is necessary for the whole system to be protected.
- For EMP-protection usually a shield as an electromagnetic barrier to protect a certain volume is necessary. This shield avoids coupling of radiated disturbances inside the protected volume. In addition to shielding all penetrating wires must be protected from conducted transient interferences by an appropriate POE (point of entry) protection.
- Use tested, high quality POE (point of entry) protection elements for all wires entering an electromagnetic shield and install these as feed-through devices, e.g. the Meteolabor® USS-1, USS-2, USP, or PLP series.

### Ordering Information / Part Number

**USS-SL-N-130** RF EMP surge protection stub

### Contact

Meteolabor AG  
Hofstrasse 92  
CH-8620 Wetzikon  
Switzerland

Telephone: +41 44 934 40 40  
Fax: +41 44 934 40 99  
E-Mail: [info@meteolabor.ch](mailto:info@meteolabor.ch)  
[www.meteolabor.com](http://www.meteolabor.com)

© by Meteolabor AG  
All rights reserved.

Content may change without further notice • 2011-04  
SL-N-130\_e\_V1-0